

Componente Component	Materiale • Component			
	Standard		A richiesta • On request	
Cassa Case	Ghisa Cast iron	EN-GJL-250	Bronzo, ghisa sferoidale Bronze, spheroidal cast iron	
Coperchio Cover	Ghisa Cast iron	EN-GJL-250	Bronzo, ghisa sferoidale Bronze, spheroidal cast iron	
Supporti Supports	Ghisa Cast iron	EN-GJL-250		
Girante Impeller	Ghisa Cast iron	EN-GJL-250	Acciaio inossidabile Stainless steel	AISI316 (1.4408)
			Bronzo Bronze	G-CuSn10
Albero Shaft	Acciaio inossidabile Stainless steel	AISI431 (1.4057)	Acciaio inossidabile Stainless steel	DUPLEX (1.4362)
Tenuta Shaft seal	Baderna Soft packing		Tenuta meccanica Mechanical seal	

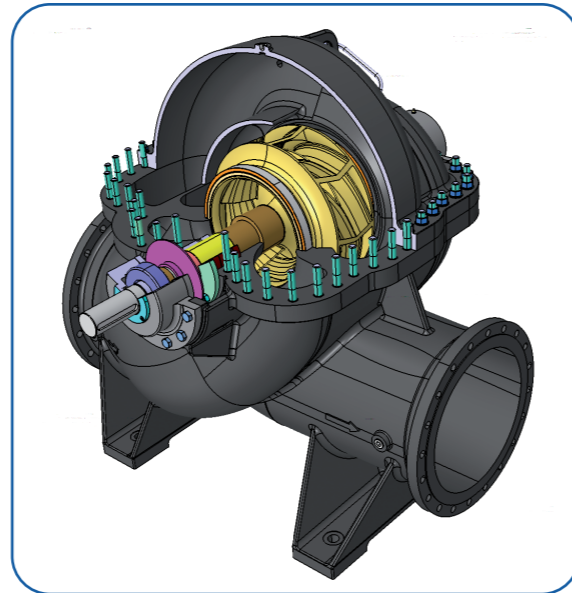

Altri materiali e versioni speciali a richiesta
Materials and special versions upon request

- La ditta si riserva la facoltà di modificare senza preavviso i dati riportati in questo catalogo.
- Saer can alter without notifications the data mentioned in this catalogue.

Prestazioni e tolleranze secondo UNI EN ISO 9906: 2012 grado 2B
Performances and tolerances according to UNI EN ISO 9906: 2012 grade 2B

SAER[®]
ELETTROPOMPE

SAER ELETTROPOMPE S.p.A.
Via Circonvallazione, 22 • 42016 Guastalla (RE) Italy
Tel. 0522.83.09.41 r. a. • Fax 0522.82.69.48
e-mail: info@saer.it - <http://www.saerelettropompe.com>



Cod. 230 - 02/2015

SAER[®]
ELETTROPOMPE

SKD
POMPE A CASSA DIVISA
SPLIT-CASING PUMPS

